

Hose reel MGLE

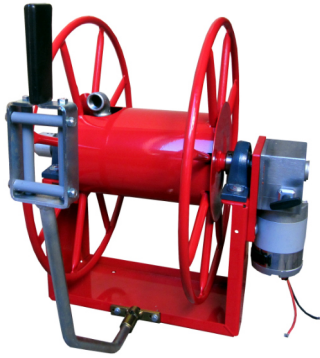

- Motor 24V DC - 400W - 20A,
- Speed 30rpm,
- Manually disengageable for motor freewheeling
- Painted steel housing
- Shaft with ball bearings
- Fixed mounting bracket
- Without hose

Item-No.	Designation	Medium	Max. length of the hose	Max. Ø	Max. pressure	Max. temp.	Motor
2.700.010	MGLE 212	Water Pesticides High pressure Diesel Oil	50m	25mm	250bar	90°C	12V, 30u/min 400W - 43A
2.700.080	MGLE 912		20m	38mm	200bar	60°C	
2.750.010	MGLE 224		50m	25mm	250bar	90°C	24V, 30u/min 400W - 20A
2.750.080	MGLE 924		20m	38mm	200bar	60°C	

Item-No. 12V Motor	Item-No. 24V Motor	A	B	kg
2.700.010	2.750.010	690	675	40
2.700.080	2.750.080	690	675	40

Optional accessories	
Item-No.	Designation
130.029	Control box, function: rolling in
130.019	Roller window with handle for MGL / MGLO / MGLE 100, 200, 1000
130.034	Roller window with handle for MGL / MGLO / MGLE 900

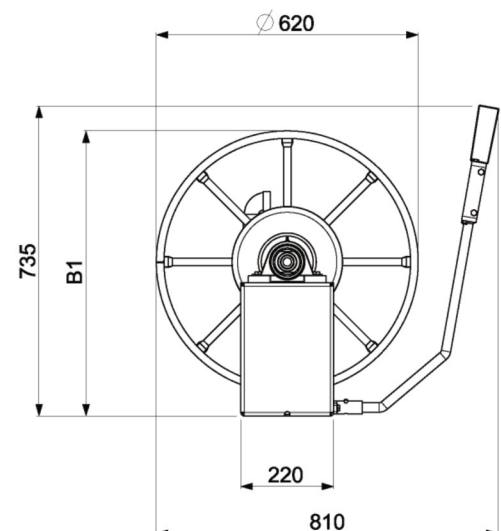
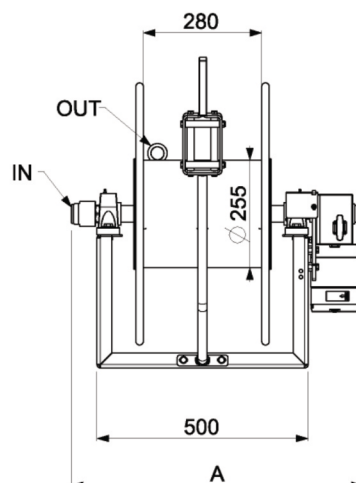
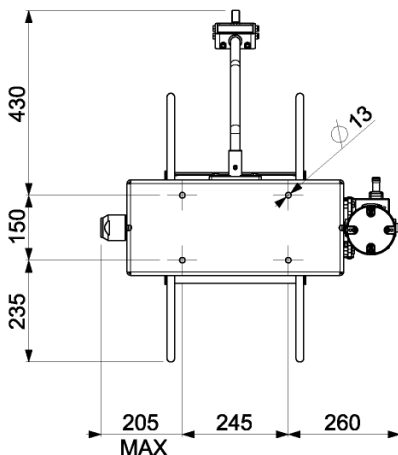

Hose reel MGLE

Item-No.	Designation	Medium	Max. length of the hose	Max. Ø	Max. pressure	Max. temp.	Motor
2.700.040	MGLE 512	Water Pesticides High pressure Diesel Oil	100m	25mm	250bar	90°C	12V, 30u/min 400W - 43A
2.700.050	MGLE 612		40m	38mm	200bar	90°C	
2.750.040	MGLE 524		100m	25mm	250bar	90°C	24V, 30u/min 400W - 20A
2.750.050	MGLE 624		40m	38mm	200bar	90°C	

Item-No. 12V Motor	Item-No. 24V Motor	A	B	kg
2.700.040	2.750.040	790	805	47
2.700.050	2.750.050	810	820	51

Optional accessories	
Item-No.	Designation
130.029	Control box, function: rolling in
130.009	Roller window with handle for MGL / MGLO / MGLE 300, 400, 500
130.022	Automatic hose guide ½" for MGL / MGLO / MGLE 300, 400, 500
130.023	Automatic hose guide ¾" for MGL / MGLO / MGLE 300, 400, 500
130.024	Automatic hose guide 1" for MGL / MGLO / MGLE 300, 400, 500

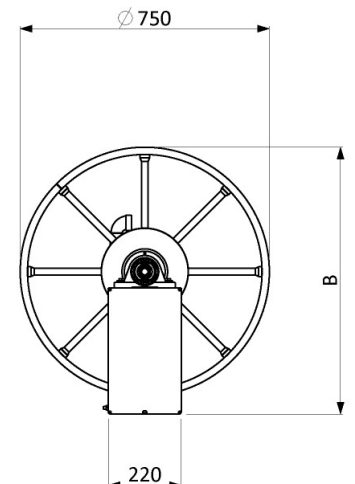
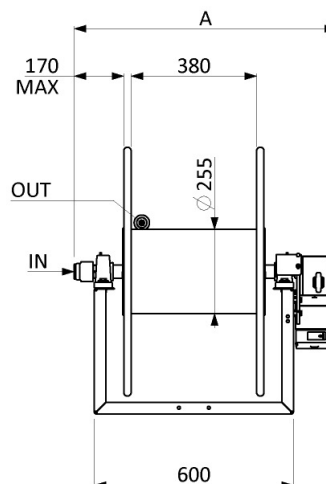
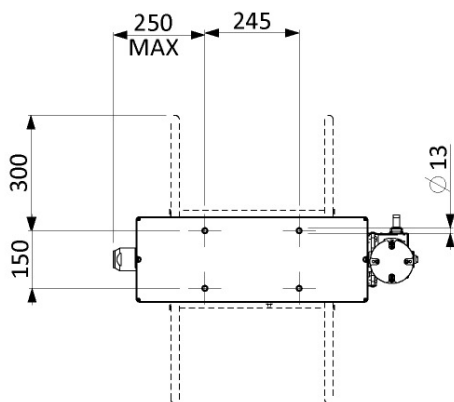

Hose reel MGLE

Item-No.	Designation	Medium	Max. length of the hose	Max. Ø	Max. pressure	Max. temp.	Motor
2.700.095	MGLE 1112	Water Pesticides High pressure Diesel Oil	18m	50mm	20bar	60°C	12V, 30u/min 400W - 43A
2.750.095	MGLE 1124		18m	50mm	20bar	60°C	24V, 30u/min 400W - 20A

Item-No. 12V Motor	Item-No. 24V Motor	A	A1	A2	A3	kg
2.700.095	2.750.095	755	425	600	520	47

Optional accessories

Item-No.	Designation
130.029	Control box, function: rolling in

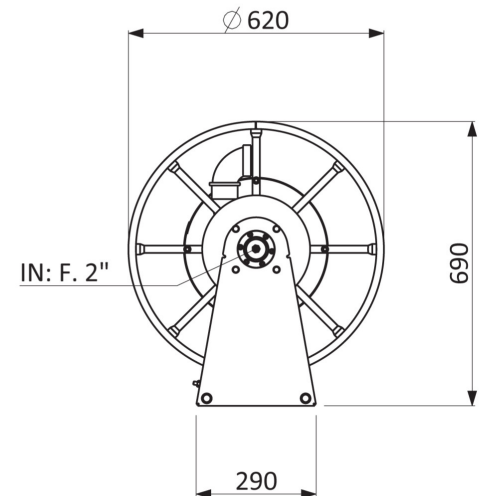
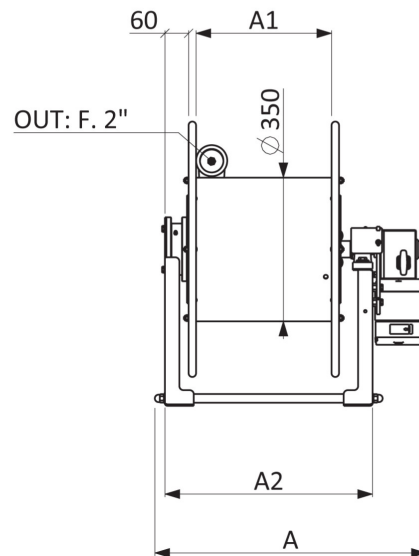
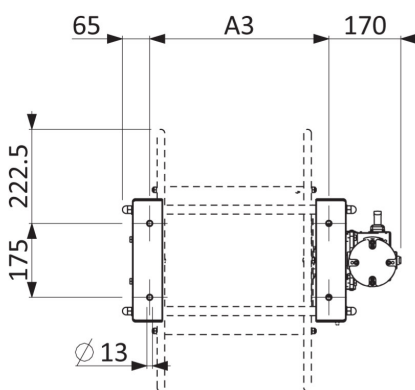

Hose reel MGLE

Item-No.	Designation	Medium	Max. length of the hose	Max. Ø	Max. pressure	Max. temp.	Motor
2.700.060	MGLE 712	Water Pesticides High pressure Diesel Oil	30m	50mm	20bar	60°C	12V, 30u/min 400W - 43A
2.700.070	MGLE 812		25m	50mm	20bar	60°C	
2.750.060	MGLE 712		30m	50mm	20bar	60°C	24V, 30u/min 400W - 20A
2.750.070	MGLE 812		25m	50mm	20bar	60°C	

Item-No. 12V Motor	Item-No. 24V Motor	A	A1	A2	A3	kg
2.700.060	2.750.060	755	425	600	520	49
2.700.070	2.750.070	655	325	500	420	47

Optional accessories

Item-No.	Designation
130.029	Control box, function: rolling in

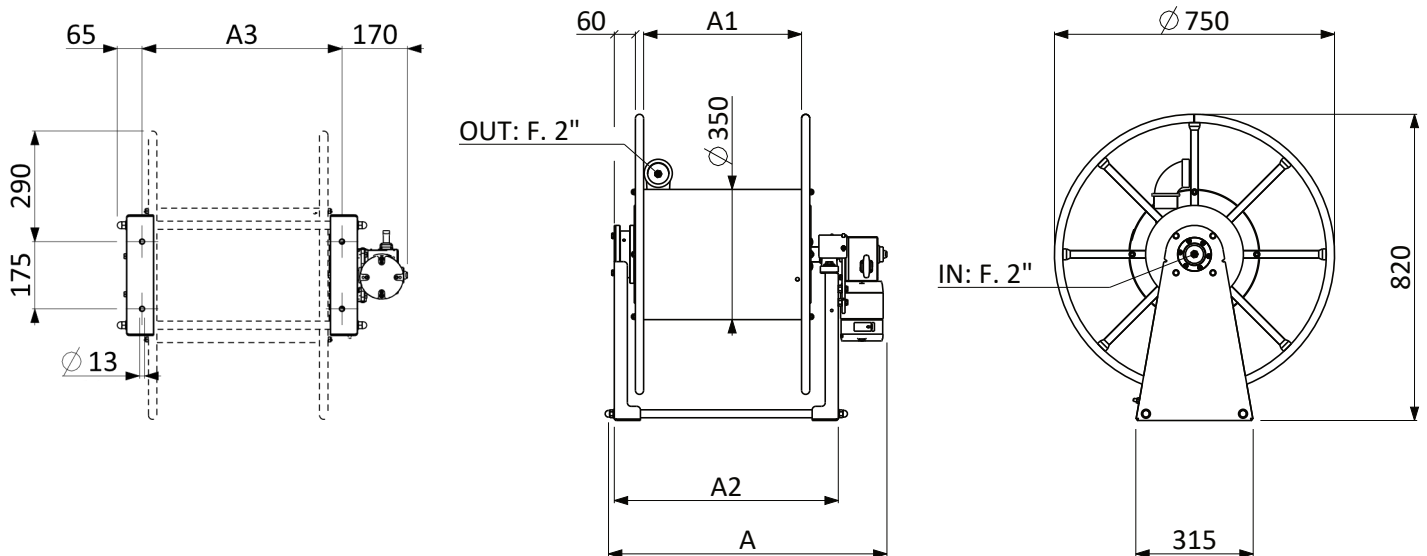

Hose reel MGLE

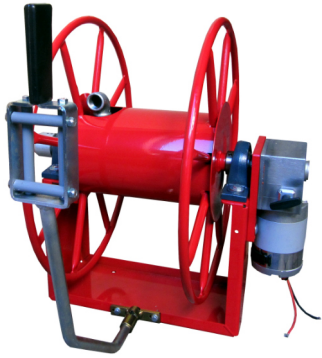

- Motor 400V AC - 550W - 1.6A
- Speed 27rpm,
- Manual pull-out with slight motor resistance,
- Painted steel housing
- Shaft with ball bearings
- Fixed mounting bracket
- Without hose

Item-No.	Designation	Medium	Max. length of the hose	Max. Ø	Max. pressure	Max. temp.	Motor
2.780.010	MGLE 240	Water Pesticides High pressure Diesel Oil	50m	25mm	250bar	90°C	230V/400V, 27U/min 2,85A/1,6A-550W
2.780.080	MGLE 940		20m	38mm	200bar	60°C	

Item-No.	A	B	kg
2.780.080	705	690	63
2.780.090	680	675	58

Optional accessories	
Item-No.	Designation
130.019	Roller window with handle for MGL / MGLO / MGLE 100, 200, 1000
130.034	Roller window with handle for MGL / MGLO / MGLE 900

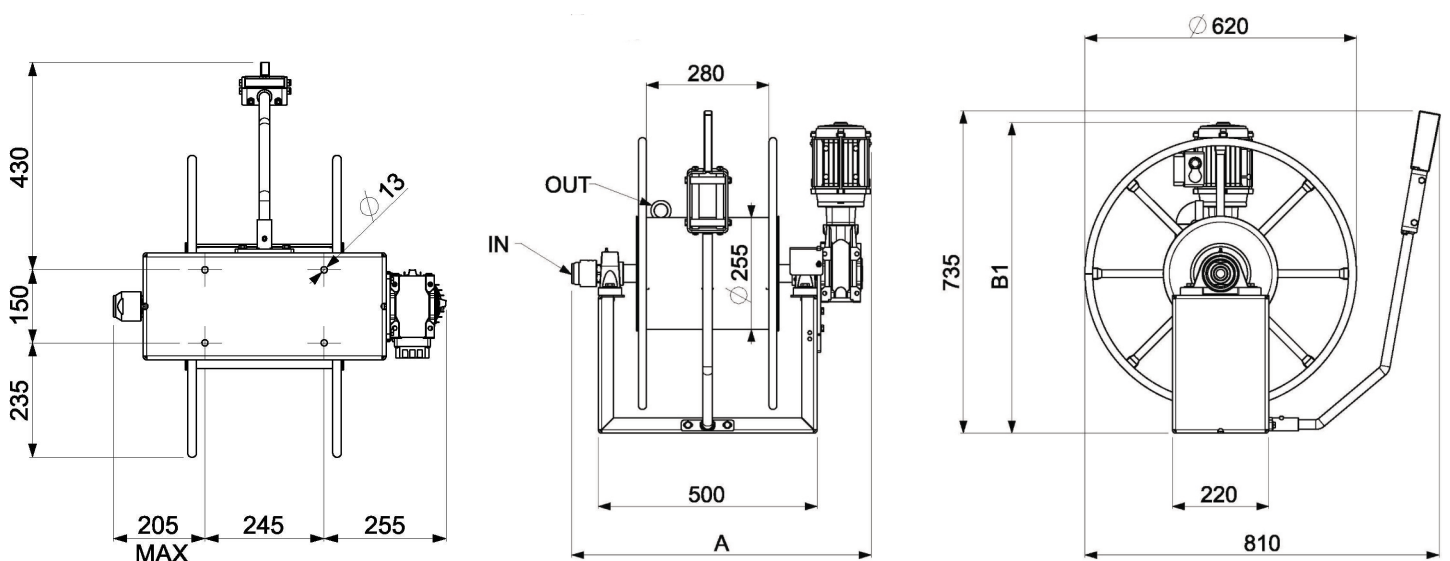

Hose reel MGLE

Item-No.	Designation	Medium	Max. length of the hose	Max. Ø	Max. pressure	Max. temp.	Motor
2.780.040	MGLE 940	Water Pesticides High pressure Diesel Oil	100m	25mm	250bar	90°C	230V/400V, 27U/min 2,85A/1,6A-550W
2.780.050	MGLE 1040		40m	38mm	250bar	90°C	

Item-No.	A	B	kg
2.780.040	785	805	66
2.780.050	805	820	70

Optional accessories	
Item-No.	Designation
130.009	Roller window with handle for MGL / MGLO / MGLE 300, 400, 500
130.022	Automatic hose guide ½" for MGL / MGLO / MGLE 300, 400, 500
130.023	Automatic hose guide ¾" for MGL / MGLO / MGLE 300, 400, 500
130.024	Automatic hose guide 1" for MGL / MGLO / MGLE 300, 400, 500

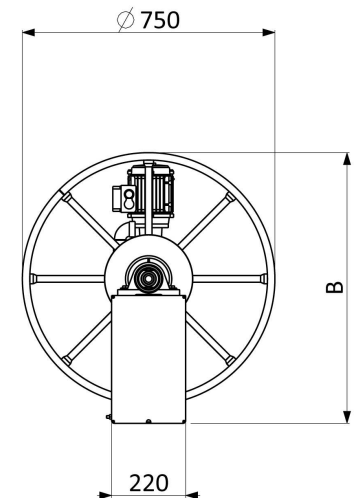
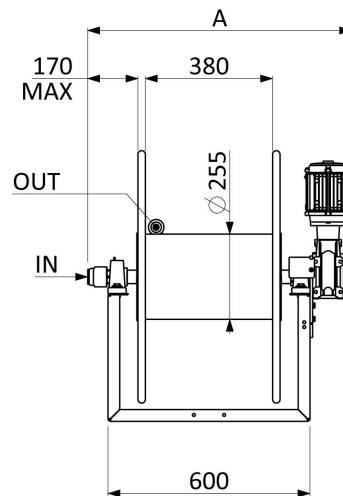
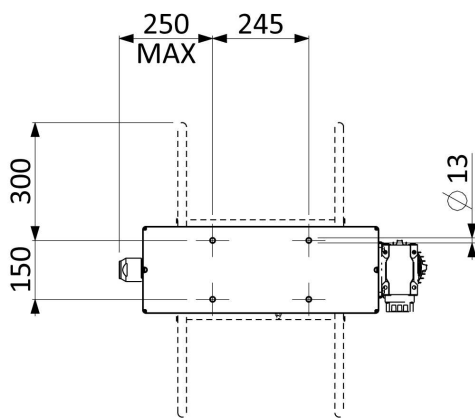

Hose reel MGLE

Item-No.	Designation	Medium	Max. length of the hose	Max. Ø	Max. pressure	Max. temp.	Motor
2.780.060	MGLE 740	Water Pesticides High pressure Diesel Oil	30m	50mm	20bar	60°C	230V/400V, 27U/min 2,85A/1,6A-550W
2.780.070	MGLE 840		25m	50mm	20bar	60°C	

Item-No.	A	A1	A2	A3	kg
2.780.060	750	425	600	520	53
2.780.070	650	325	500	420	51

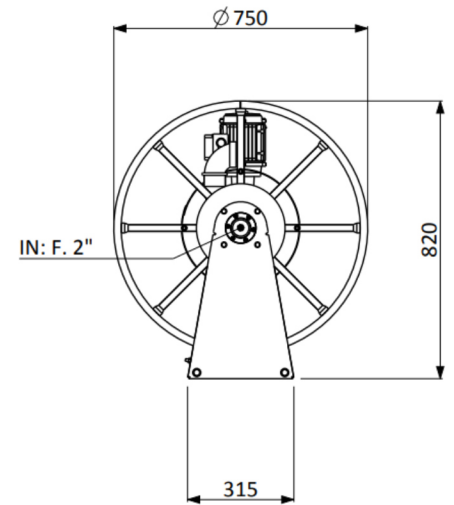
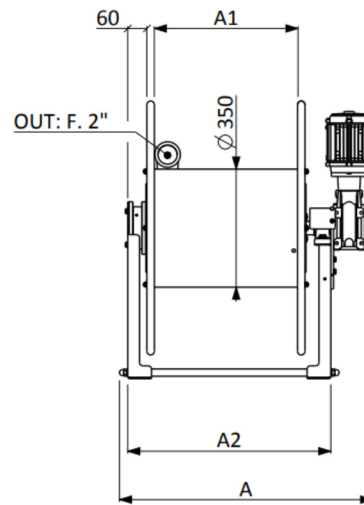
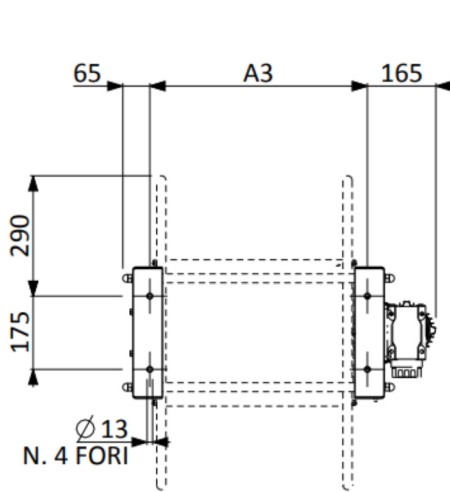

Hose reel MGLE

Item-No.	Designation	Medium	Max. length of the hose	Max. Ø	Max. pressure	Max. temp.	Motor
2.780.095	MGLE 1140	Water Pesticides High pressure Diesel Oil	18m	50mm	20bar	60°C	230V/400V, 27U/min 2,85A/1,6A-550W

Item-No.	A	A1	A2	A3	kg
2.780.095	755	425	600	518	51

