

Schlauchaufroller MGLE S

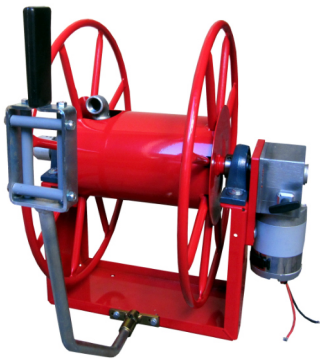

- Elektromotor 24V mit manuell zuschaltbarer Kupplung
- Steuerbox mit NOT-Aus Schalter
- Wechselakku und Ladegerät
- Gehäuse Stahl lackiert
- Achse kugelgelagert
- Montagehalter fix
- Ohne Schlauch



Artikel-Nr.	Bezeichnung	Medium	Max. Schlauchlänge	Max. Durchmesser	Max. Druck	Max. Temperatur	Motor
2.750.200	MGLE 124S	Wasser Pflanzenschutz Hochdruck Diesel Öl	80m	19mm	250bar	90°C	24V, 30u/min 400W - 20A
2.750.210	MGLE 224S		50m	25mm	250bar	90°C	
2.750.280	MGLE 924S		20m	38mm	200bar	60°C	
2.750.290	MGLE 1024S		130m	13mm	250bar	90°C	

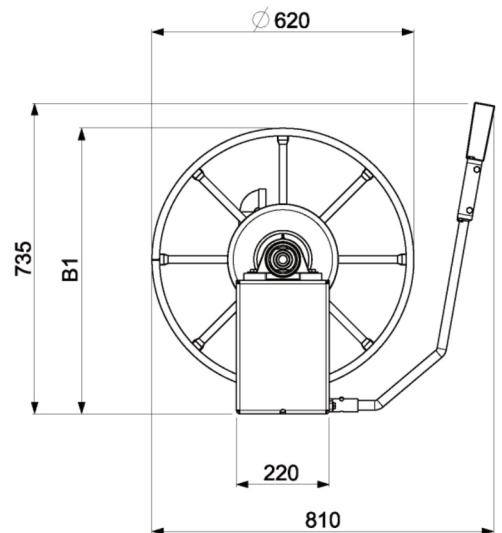
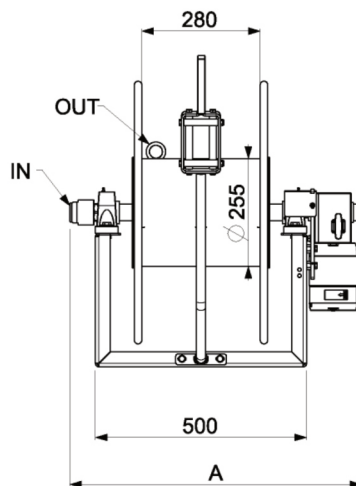
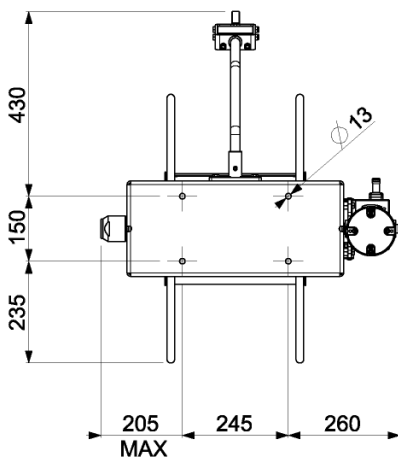

Artikel-Nr.	A	B	kg
2.750.200	745	675	39
2.750.210	750	675	40
2.750.280	750	675	40
2.750.290	770	690	45

Schlauchaufroller MGLE S

Artikel-Nr.	Bezeichnung	Medium	Max. Schlauchlänge	Max. Durchmesser	Max. Druck	Max. Temperatur	Motor
2.750.220	MGLE 324S	Wasser Pflanzenschutz Hochdruck Diesel Öl	270m	13mm	250bar	90°C	24V, 30u/min 400W - 20A
2.750.230	MGLE 424S		180m	19mm	250bar	90°C	
2.750.240	MGLE 524S		100m	25mm	250bar	90°C	
2.750.250	MGLE 624S		40m	38mm	200bar	60°C	

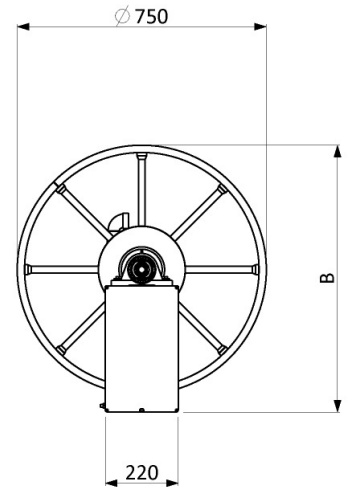
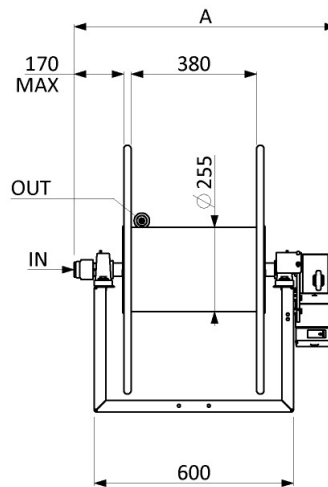
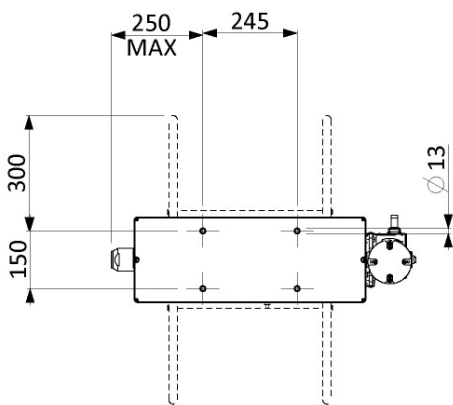

Artikel-Nr.	A	B	kg
2.750.220	845	805	46
2.750.230	850	805	47
2.750.240	850	805	47
2.750.250	870	820	51

Schlauchaufroller MGLE S

Artikel-Nr.	Bezeichnung	Medium	Max. Schlauchlänge	Max. Durchmesser	Max. Druck	Max. Temperatur	Motor
2.750.295	MGLE 1124S	Wasser Pflanzenschutz Hochdruck Diesel Öl	18m	50mm	20bar	60°C	24V, 30u/min 400W - 20A

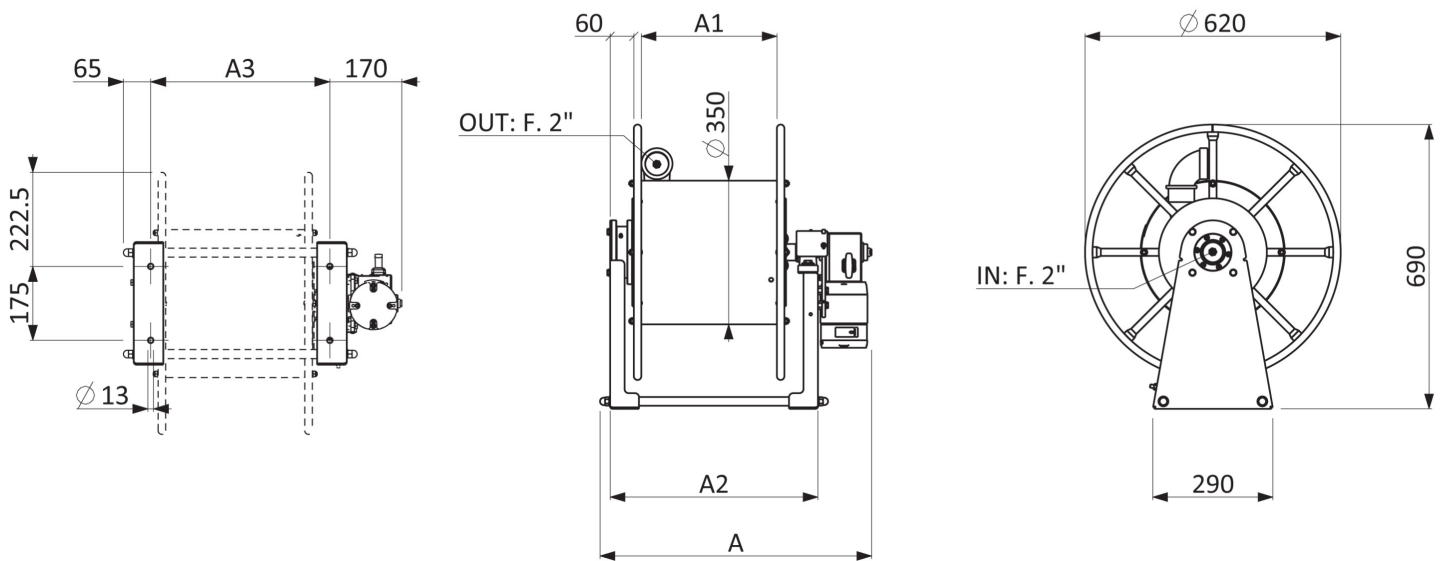

Artikel-Nr.	A	A1	A2	A3	kg
2.750.295	815	425	600	520	47

Schlauchaufroller MGLE S

Artikel-Nr.	Bezeichnung	Medium	Max. Schlauchlänge	Max. Durchmesser	Max. Druck	Max. Temperatur	Motor
2.750.260	MGLE 712S	Wasser Pflanzenschutz	30m	50mm	20bar	60°C	24V, 30u/min 400W - 20A
2.750.270	MGLE 812S	Hochdruck Diesel Öl	25m	50mm	20bar	60°C	

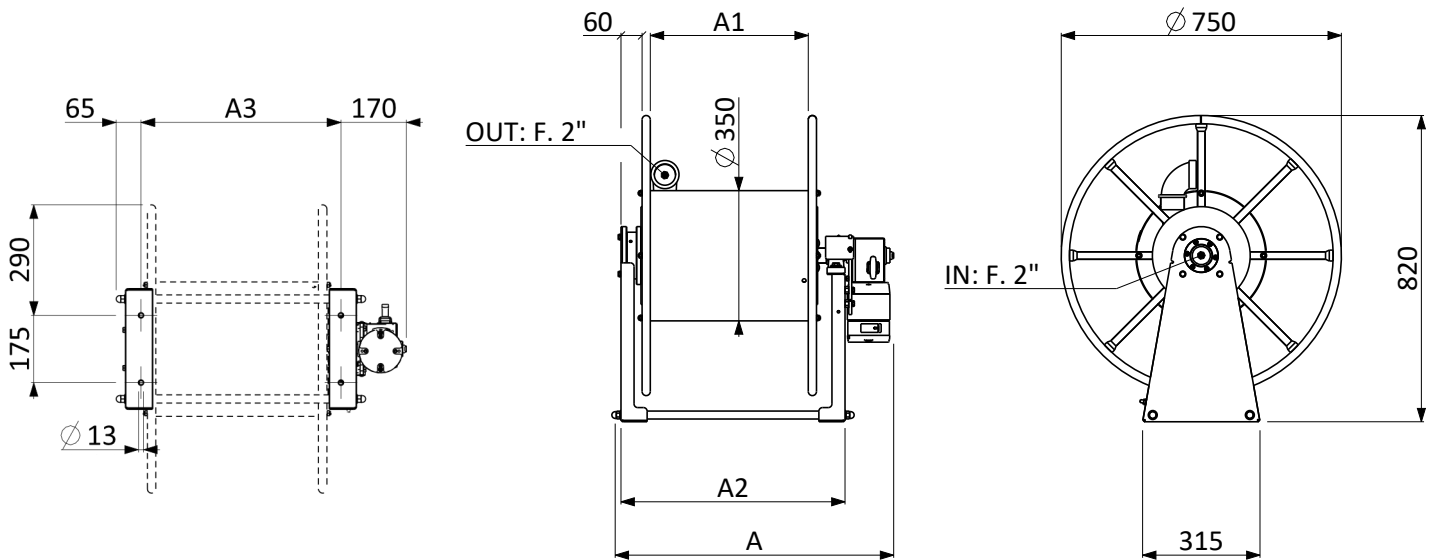

Artikel-Nr.	A	A1	A2	A3	kg
2.750.260	815	425	600	520	49
2.750.270	715	325	500	420	47

Schlauchaufroller MGLE S



- Elektromotor 230/400V mit automatischem Freilauf
- Steuerbox mit NOT-Aus Schalter
- Gehäuse Stahl lackiert
- Achse kugelgelagert
- Messing Drehgelenk
- Montagehalter fix
- Ohne Schlauch

Artikel-Nr.	Bezeichnung	Medium	Max. Schlauchlänge	Max. Durchmesser	Max. Druck	Max. Temperatur	Motor
2.780.200	MGLE 140S	Wasser Pflanzenschutz Hochdruck Diesel Öl	100m	19mm	250bar	90°C	230V/400V, 27U/min 2,85A/1,6A-550W
2.780.210	MGLE 240S		50m	25mm	250bar	90°C	
2.780.280	MGLE 940S		20m	38mm	200bar	60°C	
2.780.290	MGLE 1040S		130m	13mm	250bar	90°C	

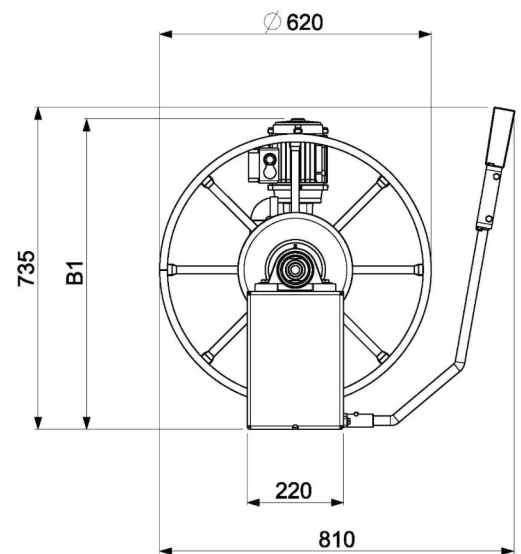
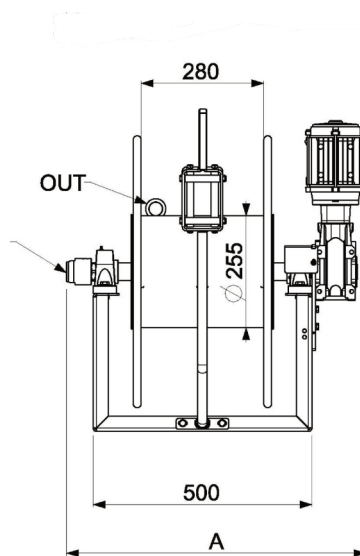
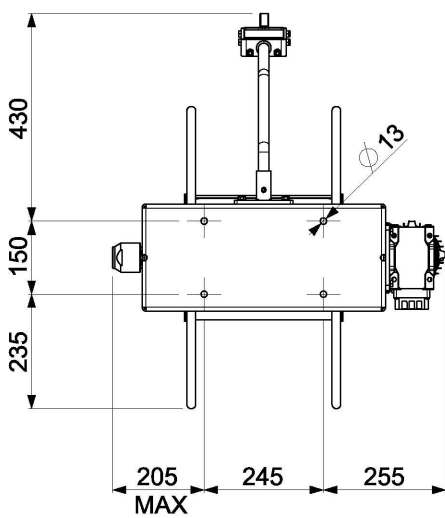

Artikel-Nr.	A	B	kg
2.780.200	765	675	58
2.780.210	765	675	59
2.780.280	785	690	63
2.780.290	760	675	58

Schlauchaufroller MGLE S

Artikel-Nr.	Bezeichnung	Medium	Max. Schlauchlänge	Max. Durchmesser	Max. Druck	Max. Temperatur	Motor
2.780.220	MGLE 140S	Wasser Pflanzenschutz Hochdruck Diesel Öl	270m	13mm	250bar	90°C	230V/400V, 27U/min 2,85A/1,6A-550W
2.780.230	MGLE 240S		180m	19mm	250bar	90°C	
2.780.240	MGLE 940S		100m	25mm	250bar	90°C	
2.780.250	MGLE 1040S		40m	38mm	250bar	90°C	

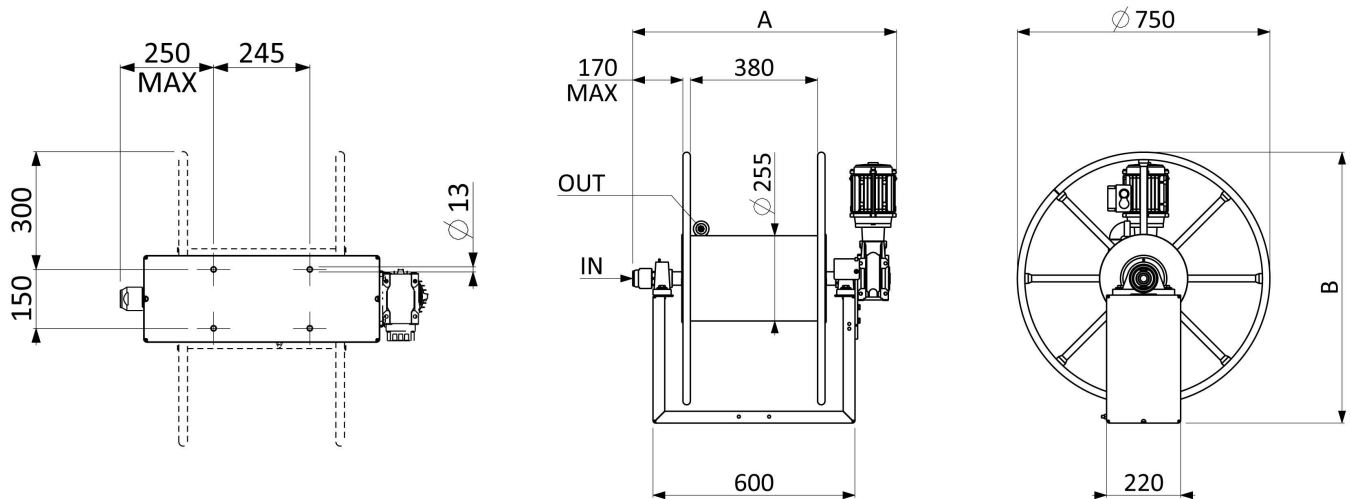

Artikel-Nr.	A	B	kg
2.780.220	860	805	65
2.780.230	865	805	65
2.780.240	865	805	66
2.780.250	885	820	70

Artikel-Nr.	Bezeichnung	Medium	Max. Schlauchlänge	Max. Durchmesser	Max. Druck	Max. Temperatur	Motor
2.780.260	MGLE 740S	Wasser Pflanzenschutz Hochdruck Diesel Öl	30m	50mm	60bar	20°C	230V/400V, 27U/min 2,85A/1,6A-550W
2.780.270	MGLE 840S		25m	50mm	60bar	20°C	
2.780.295	MGLE 1140S		18m	50mm	60bar	20°C	

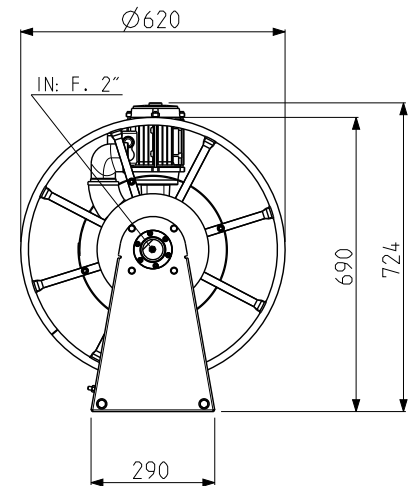
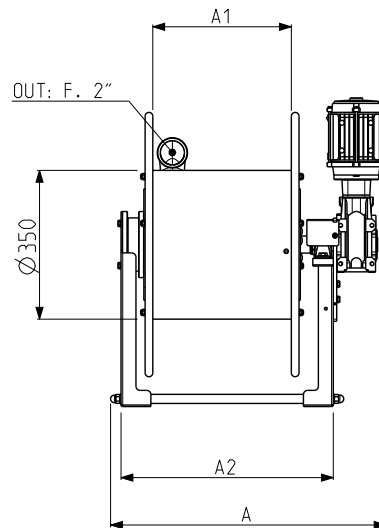
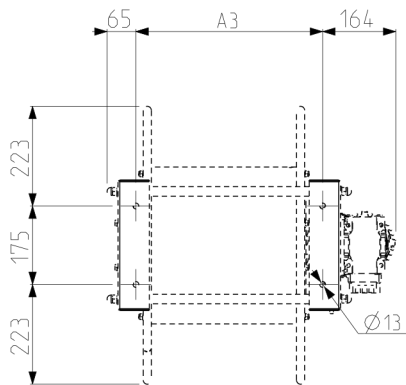

Artikel-Nr.	A	A1	A2	A3	kg
2.780.260	830	425	600	520	53
2.780.270	730	325	500	420	51
2.780.295	835	425	600	518	51

